

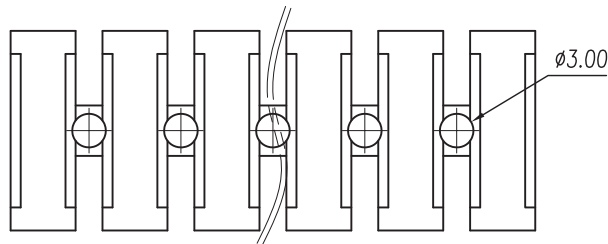

# CIXI WANJIE ELECTRONIC CO., LTD

THE SPEC SHEET

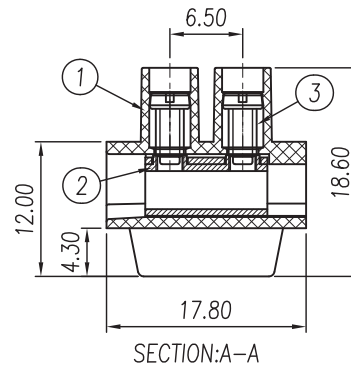
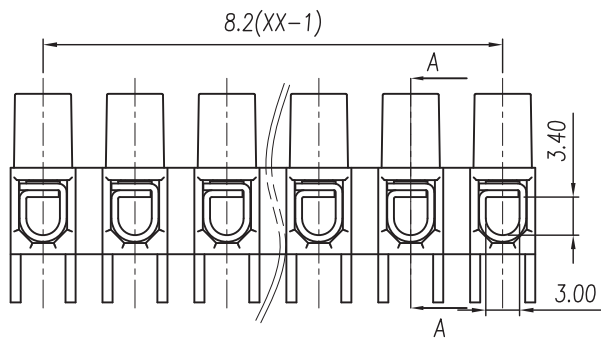
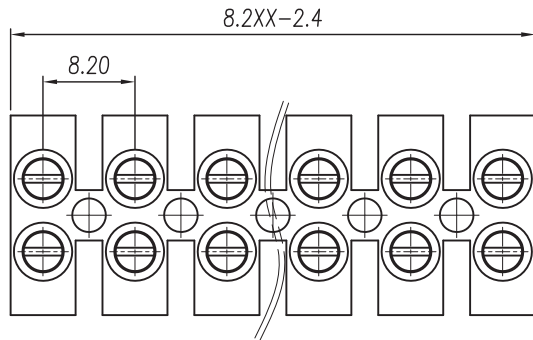

### Electrical

Standard	UL	IEC
Rated voltage	300V	450V
Rated current	15A	32A
Contact resistance	20mΩ	
Insulation resistance	500MΩ/DC500V	
Wire range	20~10AWG	0.5-4.0mm <sup>2</sup>
Wrth standing voltage	AC 2000V/1 Min	

### Mechanical

Torque	0.4Nm(3.6Lb.in)
Steip Length	7-8mm
Temp.Range	-40°C~+105°C

### Dimensions

Pitch	8.2mm
Poles	2-12p

### Material

Housing	PA66, UL94V-2
Screws	M2.5 Steel, Zn plated
Pressure line column	SPCC Zn plated

linear dimension(Tolerances Standard GB/T 14486-2008)

variable range	linear dimension(Tolerances Standard GB/T 14486-2008)											≡	—	□	//	⊥
	to 6	over 6 to 10	over 10 to 18	over 18 to 30	over 30 to 50	over 50 to 80	over 80 to 120	over 120 to 160	over 160 to 200	over 200 to 250	to 250					
tolerance	±0.1	±0.14	±0.19	±0.25	±0.32	±0.43	±0.57	±0.72	±0.88	±1.05	±1.25	0.5	0.025	0.06	0.12	0.4

UNITS	mm	SIZE	A4	SCALE	1.5:1	THIRD ANGLE PROJECTION	
CIXI WANJIE ELECTRONIC CO., LTD							
TITLE						MY8HS+4.3-8.2-XXP-1YY-00A	